

BIO-FIGHTER® 4XTREME

Features

- Suitable for extreme indoor/outdoor applications
- NEMA 4X housing
- Quick-release lamp retention system
- High-output germicidal bulbs
- Multi-voltage, multi lamp length electronic ballast
- ETL safety agency listing to UL 1598
- Tilt-lamp capability
- Cover safety interlock
- In-line fuse
- Limited lifetime warranty



Whether it is Mother Nature or a splash of coil cleaner, the Bio-Fighter® 4Xtreme rooftop UV-C fixture, equipped with a UL listed NEMA 4X interlocked enclosure, can handle the harshest of HVAC environments. Many rooftop AHUs are candidates for high power commercial UV-C fixtures and the 4Xtreme is the Bio-Fighter® for the job. The multi-input voltage power supply rated for 120V to 240V, along with your choice of three lamps lengths, provides the installer with a very compatible UV-C fixture for the majority of roof-top applications.



NEMA 4X rated housing protects internal components against moisture and corrosion.

Large T6 HO lamps are custom designed with cathode rings to maximize UV-C power and efficiency.

User friendly slide-clip lamp retention system makes bulb replacement easier.

Cover interlock ensures user safety by preventing unit operation while cover is open.

Smart ballast technology senses input voltage and automatically adjusts for 120V or 240V power.

Tilt-lamp feature increases the amount of UV-C dosage into water located in the drain pan.

Outdoor Use



Choose A Length

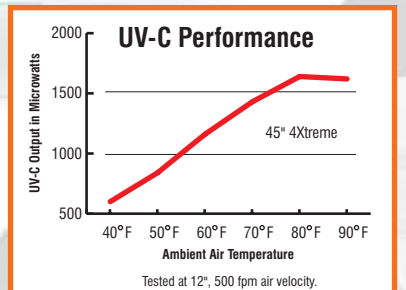
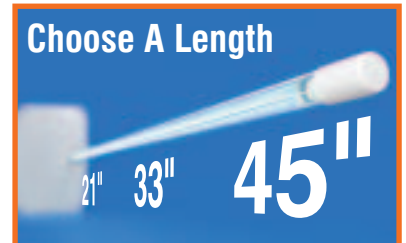

BIO-FIGHTER®
4XTREME
Germicidal Ultraviolet Light

Submittal

The Bio-Fighter® 4Xtreme assists in preventing the growth of micro-organism contaminants in commercial or outdoor applications. To ensure maximum effectiveness, install and maintain the Bio-Fighter® in accordance with installation and maintenance instructions.

Dimensions: See Fig.1

Weight:

All models - 8.2 lbs.

Lamp:

9000 hour lamp life.

Listings:

ETL Safety Agency - File #2002554

FIFRA - File #73316

Electrical:

The 4Xtreme uses a multi-voltage electronic ballast able to operate within a range of 120 to 240 volts. The unit is to be hard-wired to an appropriate electrical service in accordance with NEC.

Power Ratings: 120V - 240V, 50/60 Hz.

Full Load Amps: 120V - .90 Amps. 240V - .50 Amps.

Temperature:

45 F - 150 F (Outside of duct).

UV-C Output ($\mu\text{w}/\text{cm}^2$):	
4Xtreme 21"	720
4Xtreme 33"	750
4Xtreme 45"	840

Tested at 50 F, 12", 500FPM air velocity.

Fig. 1 Dimensions of 4Xtreme.

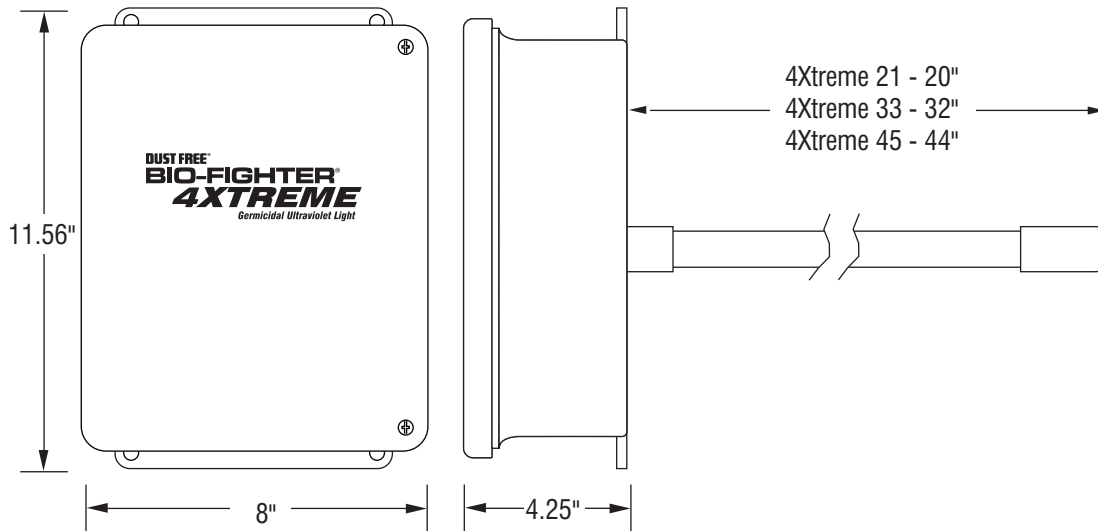

Specifications subject to change without notice.

Qty	P/N	Description
	06159	Bio-Fighter® 4Xtreme 21"
	06160	Bio-Fighter® 4Xtreme 33"
	06168	Bio-Fighter® 4Xtreme 45"

Customer	_____
Project	_____
Engineer	_____
PO Number	_____



PO Box 519 • Royse City, TX 75189
1-800-441-1107
[Http://www.dustfree.com](http://www.dustfree.com)
 E-mail: sales@dustfree.com